

DuoPower

The duo of power and intelligence



Wall applications



Wall consoles

6

Applications

- TV consoles
- Lighting
- Shelves
- Mirror cabinets
- Letter boxes
- Pictures
- Fixing blinds
- Curtain rails
- Wash basin fixings
- Plumbing and heating fixings
- Bath and toilet installations
- Wall cabinets
- Range hood

Advantages

- Two component materials for top load values and intelligent functioning (expansion, folding, knotting), depending on building material - solid, perforated or panel material.
- Great feedback (feel-good-factor) of the plug. You can feel exactly when the plug is installed perfectly.
- The narrow plug rim prevents slipping into the drill hole.
- The serrated anti-rotation feature interlock in the building material and prevents rotation in the drill hole during installation.
- The greater anchorage depth of the DuoPower 6 x 50, 8 x 65 and 10 x 80 means that the plug is especially suited to fixings in hollow building materials, aerated concrete and to bridge plaster.

Certificates



Building materials

- Concrete
- Solid brick
- Solid sand-lime brick
- Aerated concrete
- Vertically perforated brick
- Perforated sand-lime brick
- Plasterboard
- Gypsum plasterboard and gypsum fibreboards
- Hollow blocks made from lightweight concrete
- Cavity floor slabs made from bricks and concrete or similar
- Natural stone
- Chipboard
- Solid panel made from gypsum
- Solid brick made from lightweight concrete

Functioning

- The grey component made from high quality nylon automatically activates for the optimum product function (expansion, folding, knotting) for the best hold.
- The red expansion wings support the safe expansion and offer additional safety for the grey component.
- The smooth-running opening allows the simple positioning of the screw and the secure guiding and fixing in the screw channel.
- The required screw length is given by the plug length + fixture thickness + the screw diameter.
- Suitable for wood and chipboard screws, as well as stud screws.
- In the case of fixing boards, the threadless part of the screw must not be longer than the fixture.

Installation in solid building materials

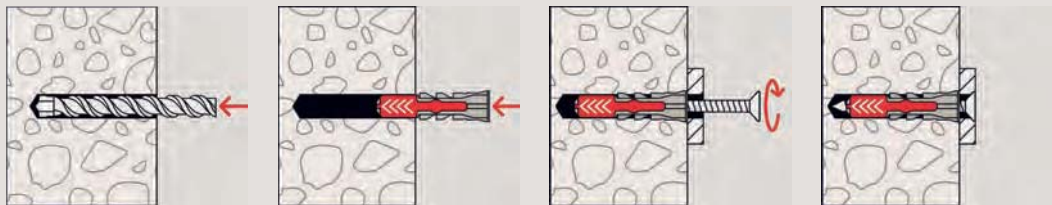

Installation in hollow building materials

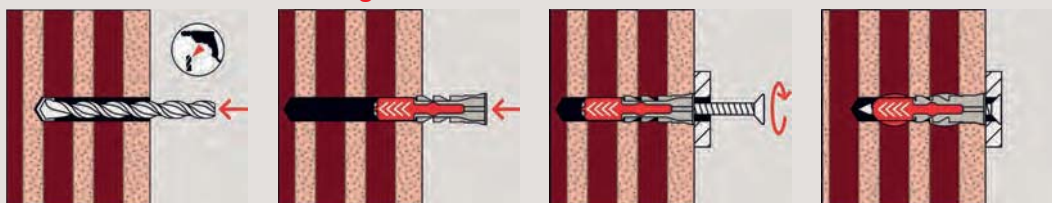

Installation in panel building materials

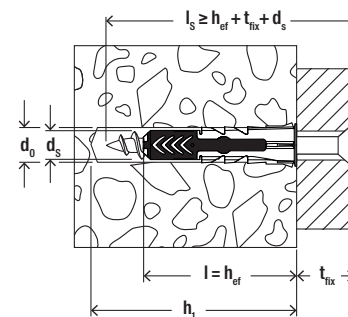
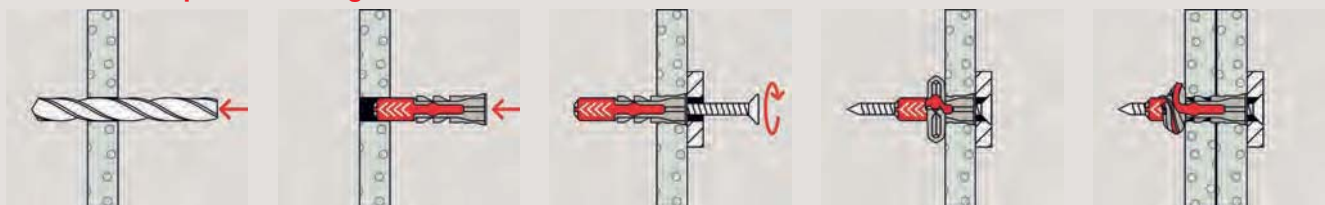

Technical data

2-component plug DuoPower



DuoPower



DuoPower with greater anchorage depth

Item	without screw	with screw	Drill hole diameter	Min. drill hole depth	Min. panel thickness	Min. bolt penetration	Anchor length	Wood and chipboard screws	Drive	Max. fixture thickness	Sales unit
	Item No.	Item No.	d_0 [mm]	h_1 [mm]	d_p [mm]	$l_{E,min}$ [mm]	l [mm]	$d_s / d_s \times l_s$ [mm]		t_{fix} [mm]	[pcs]
DuoPower 5 x 25	555005	—	5	35	12,5	29	25	3 - 4	—	—	100
DuoPower 6 x 30	555006	—	6	40	12,5	35	30	4 - 5	—	—	100
DuoPower 6 x 50	538240	—	6	60	12,5	55	50	4 - 5	—	—	100
DuoPower 8 x 40	555008	—	8	50	12,5	46	40	4,5 - 6	—	—	100
DuoPower 8 x 65	538241	—	8	75	2 x 12,5	71	65	4,5 - 6	—	—	50
DuoPower 10 x 50	555010	—	10	60	12,5	58	50	6 - 8	—	—	50
DuoPower 10 x 80	538242	—	10	100	—	88	80	6 - 8	—	—	25

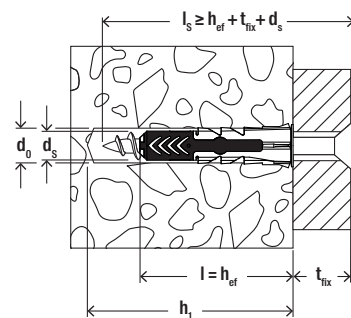

Technical data

2-component plug DuoPower



DuoPower



DuoPower with greater anchorage depth

6

Item	without screw	with screw	Drill hole diameter	Min. drill hole depth	Min. panel thickness	Min. bolt penetration	Anchor length	Wood and chipboard screws	Drive	Max. fixture thickness	Sales unit
	Item No.	Item No.	d_0 [mm]	h_1 [mm]	d_p [mm]	$l_{E,min}$ [mm]	l [mm]	$d_s / d_s \times l_s$ [mm]			
DuoPower 12 x 60	538243	—	12	90	—	70	60	8 - 10	—	—	25
DuoPower 14 x 70	538244	—	14	90	—	82	70	10 - 12	—	—	20
DuoPower 5 x 25 S	—	555105	5	40	12,5	29	25	3,5 x 35	PZ2	6	50
DuoPower 6 x 30 S	—	555106	6	45	12,5	35	30	4,5 x 40	PZ2	5	50
DuoPower 6 x 30 S PH TX	—	545838	6	45	12,5	34	30	4,5 x 40	—	6	100
DuoPower 6 x 50 S	—	538245	6	65	12,5	55	50	4,5 x 60	PZ2	5	50
DuoPower 8 x 40 S	—	555108	8	60	12,5	45	40	5 x 55	PZ2	15	50
DuoPower 8 x 65 S	—	538246	8	85	2 x 12,5	70	65	5 x 80	PZ2	10	25
DuoPower 10 x 50 S	—	555110	10	74	12,5	57	50	7 x 69	SW 13 / TX 40	13	25
DuoPower 10 x 80 S	—	538247	10	112	—	87	80	7 x 107	SW 13	20	10
DuoPower 12 x 60 S	—	538248	12	85	—	68	60	8 x 80	SW 13	12	10
DuoPower 14 x 70 S	—	538249	14	100	—	80	70	10 x 95	SW 17	15	8

Loads

DuoPower

Highest recommended loads¹⁾ for a single anchor.
The given loads are valid for wood screws with the specified diameter.

Type		5 x 25	6 x 30	6 x 50	8 x 40	8 x 65	10 x 50	10 x 80	12 x 60	14 x 70	
Wood screw diameter	[mm]	4	5	5	6	6	8	8	10	12	
Min. edge distance concrete	c_{min} [mm]	30	35	35	50	50	65	65	80	100	
Recommended loads in the respective base material F_{rec} ²⁾											
Concrete	≥ C20/25	[kN]	0.40	0.95	1.65	1.10	2.30	2.15	4.20	3.30	5.30
Solid brick	≥ Mz 12	[kN]	0.30	0.50	0.55	0.62	0.69	1.20	1.45	1.30	1.35
Solid sand-lime brick	≥ KS 12	[kN]	0.50	1.00	1.60	1.25	2.25	2.20	3.85	2.80	4.50
Aerated concrete	≥ AAC 2 (G2)	[kN]	0.05	0.10	0.15	0.10	0.16	0.20	0.30	0.24	0.35
Aerated concrete	≥ AAC 4 (G4)	[kN]	0.25	0.38	0.55	0.42	0.60	0.60	1.10	1.00	1.45
Vertically perforated brick	≥ Hlz 12 ($\rho \geq 0.9 \text{ kg/dm}^3$)	[kN]	0.13	0.15	0.17	0.25	0.40	0.25	0.40	0.35	0.40
Perforated sand-lime brick	≥ KSL 12 ($\rho \geq 1.6 \text{ kg/dm}^3$)	[kN]	0.40	0.60	0.60	0.70	1.00	0.70	2.00	0.75	1.50
Gypsum block	($\rho \geq 0,9 \text{ kg/dm}^3$)	[kN]	0.10	0.18	0.37	0.25	0.50	0.35	0.65	0.50	0.50
Gypsum fibreboard	12.5 mm	[kN]	0.24	0.33	0.35	0.35	-	0.50	-	-	-
Gypsum plasterboard	12.5 mm	[kN]	0.12	0.15	0.15	0.15	-	0.15	-	-	-
Gypsum plasterboard	2 x 12.5 mm	[kN]	0.13	0.15	0.24	0.20	0.32	0.30	-	-	-
Mattone Forato Typ F8		[kN]	0.30	0.30	-	0.25	-	0.25	-	-	-
Tramezza Doppio UNI 19		[kN]	0.15	0.15	0.23	0.15	0.30	0.20	0.52	0.35	0.35
Sepa Parpaing		[kN]	0.30	0.45	0.25 ³⁾	0.45	0.45 ³⁾	0.45	0.45 ³⁾	0.60 ³⁾	0.60 ³⁾

¹⁾ Required safety factors are considered.

²⁾ Valid for tensile load, shear load and oblique load under any angle.

³⁾ Load determination on plastered wall.